

Diaper Directions

(For Grace Children's Hospital in Haiti, through International Child Care)

Use NEW plain or printed flannel or birds-eye fabric.

1. Fold in $\frac{1}{2}$ " to $\frac{3}{4}$ " of the short ends of 36" x 12" diaper fabric, and press.
2. Fold 16" x 16" padding piece in half, lengthwise. Center padding on upper half of diaper, and zig-zag it to the diaper. (Fig. 1)
3. Fold diaper in half with right sides together. Stitch on the two long side, near the edge. (Fig. 2)
4. Turn diaper right side out and stitch all four sides, close to edge.
5. Stitch around padding and through the middle. (Fig. 3)
6. Diaper ties: Cut 2 pieces of twill tape (or grosgrain ribbon) 36" long. Center a piece of twill tape $1\frac{1}{2}$ " from the short edge of the diaper, stitch down through the diaper, on both edges of the twill tape. Attach second piece of twill tape 1" below the first. (Fig. 4)

Fig. 1

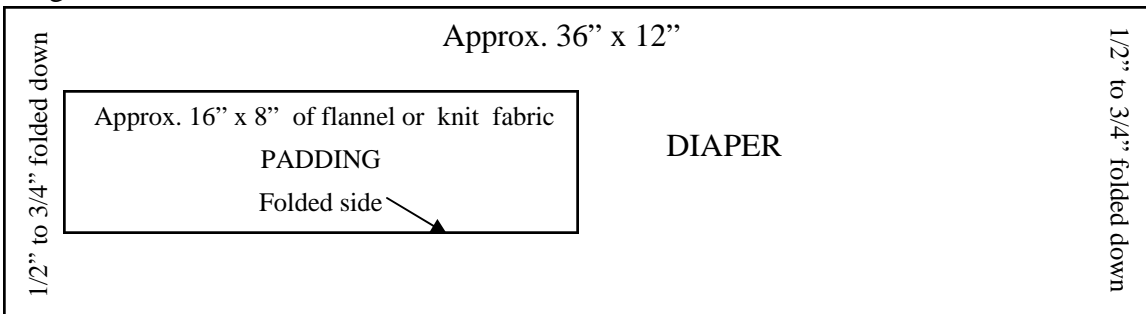

Fig. 2



Fig. 3

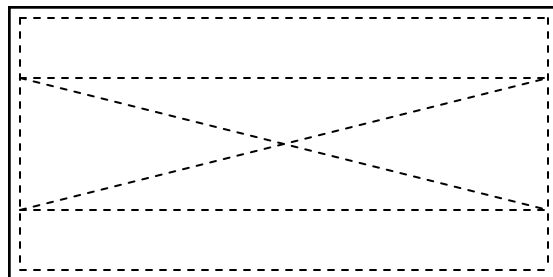
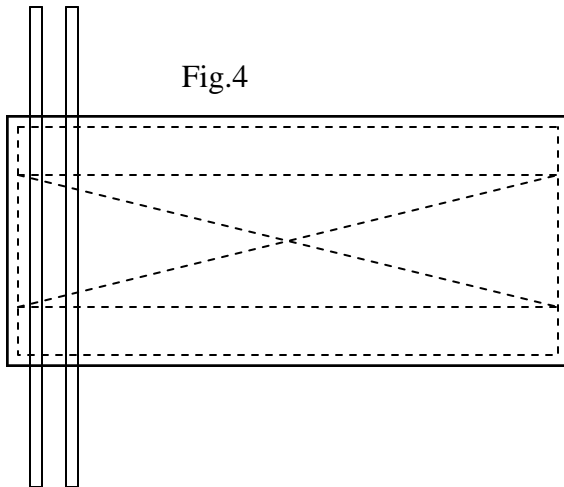

Fig. 4



Bring to

Midwest Mission Distribution Center
1022 New City Road
P O Box 56
Chatham, IL 62629-0056
1-217-483-7911
midwestmissiondc@aol.com

to be shipped to Haiti